

A who has free facings until the end, will not appear again on floor plan.

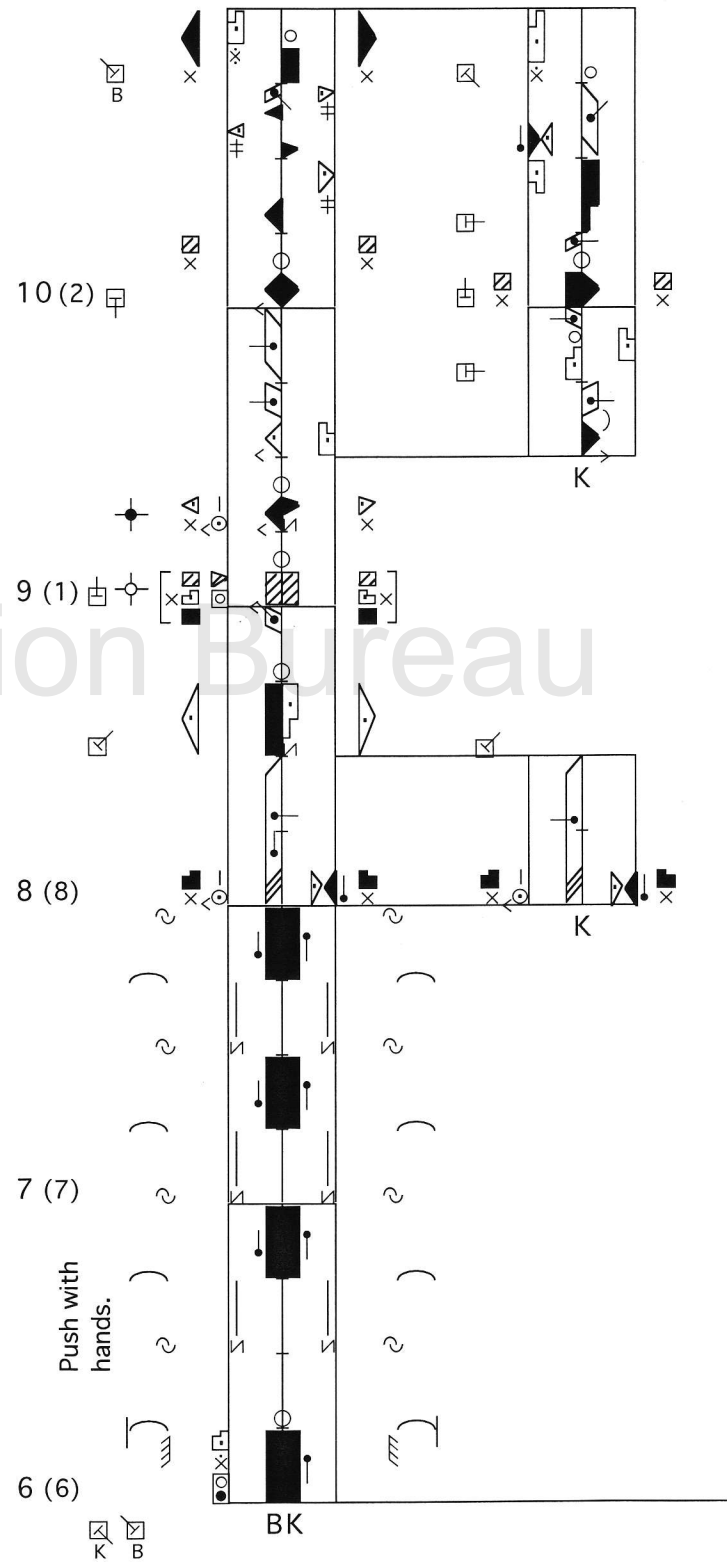

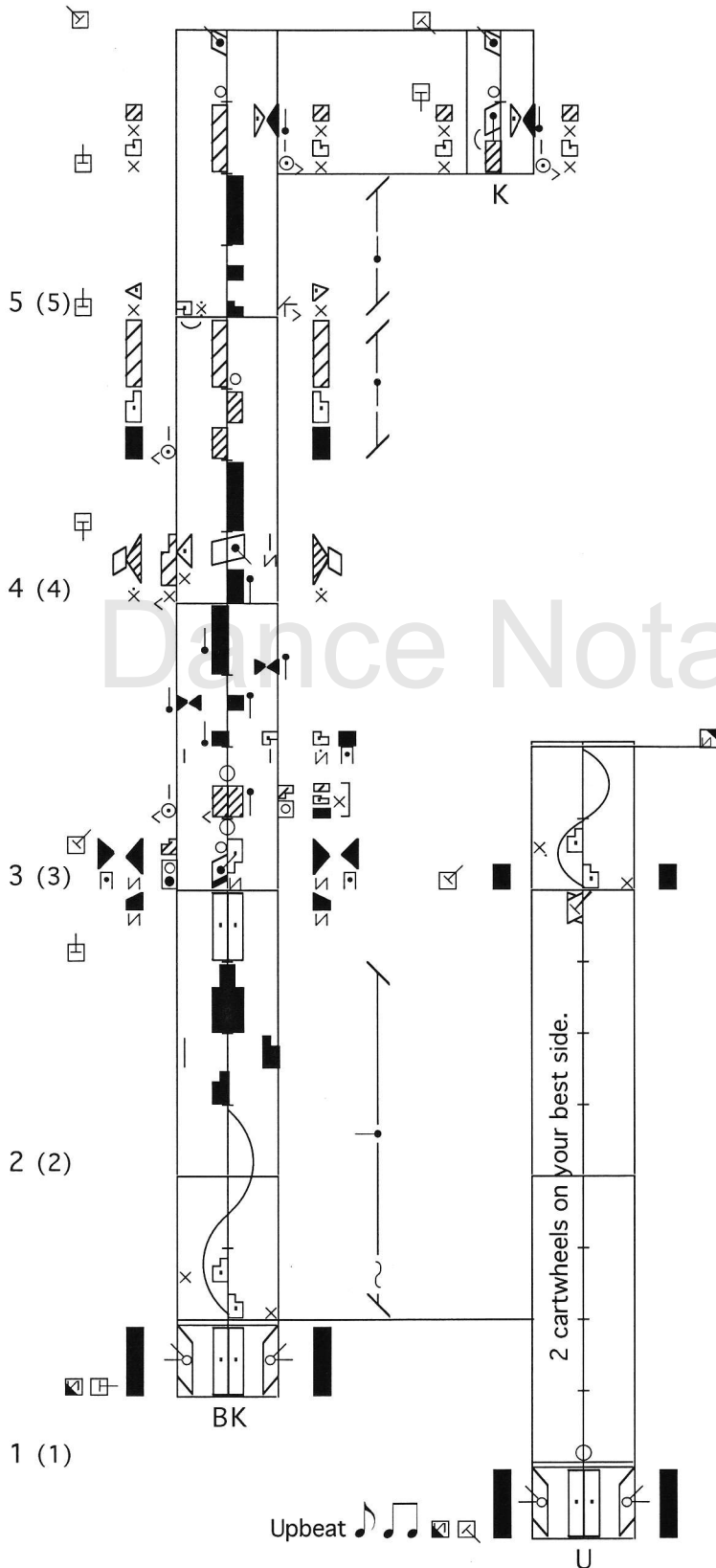

* May be done this way.

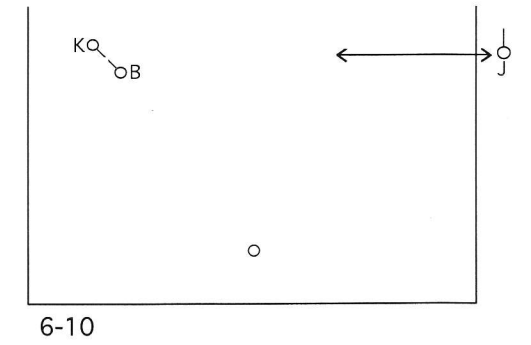
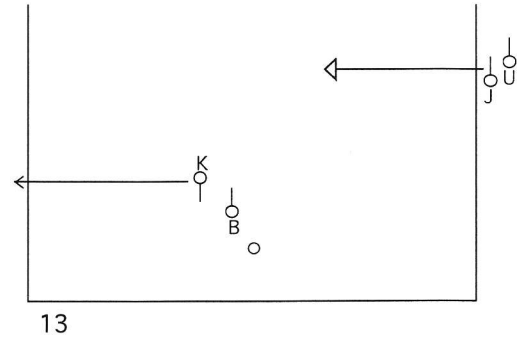
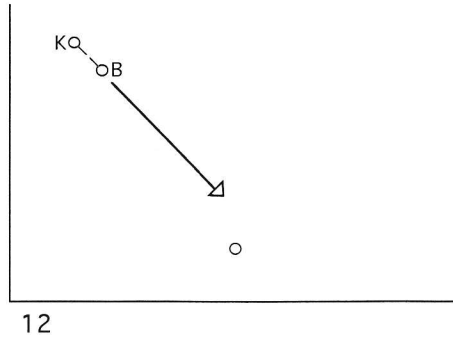
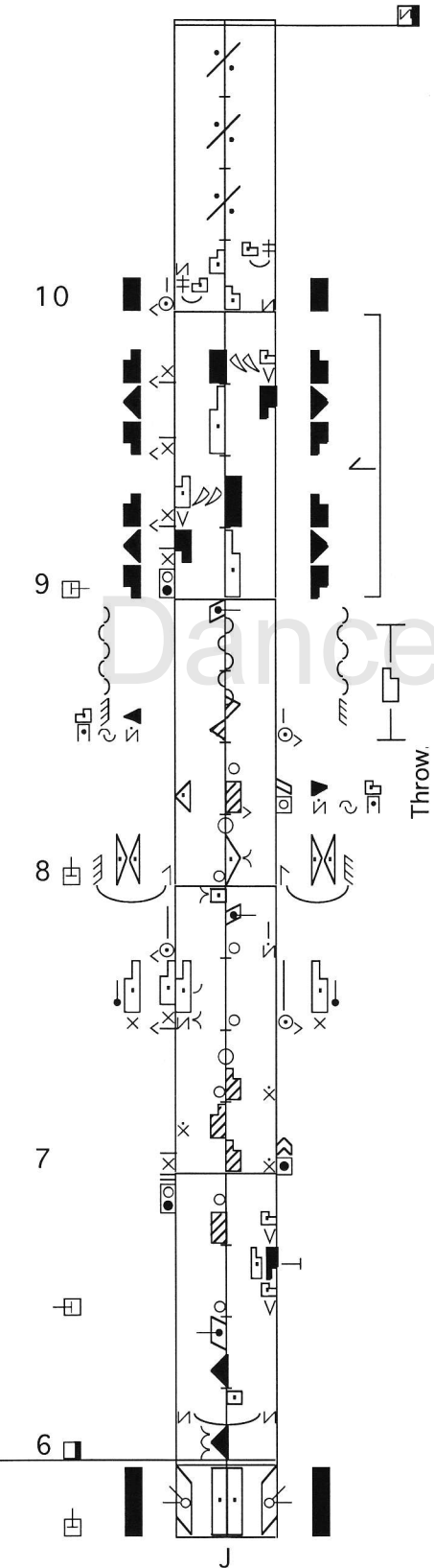
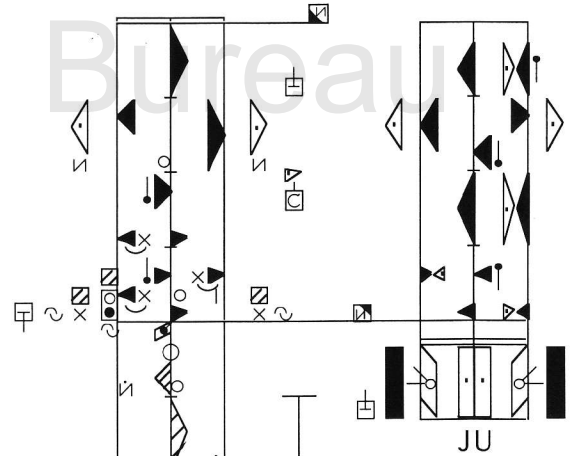
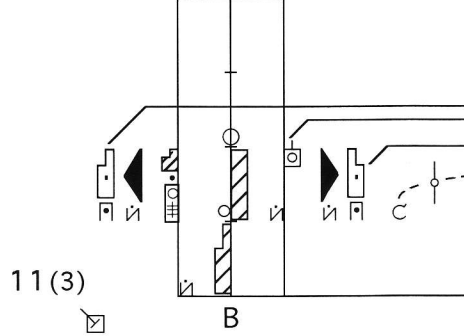
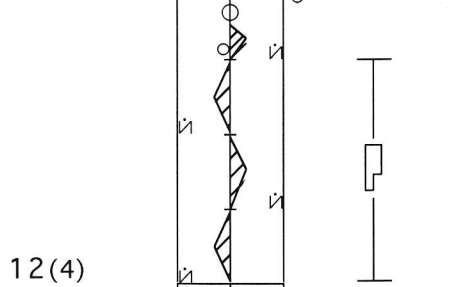
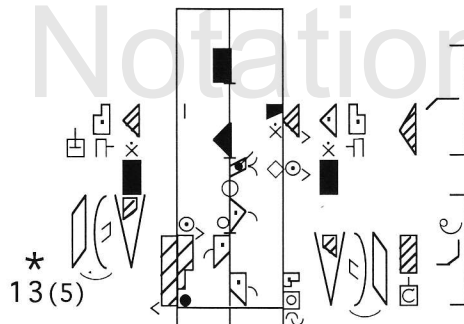

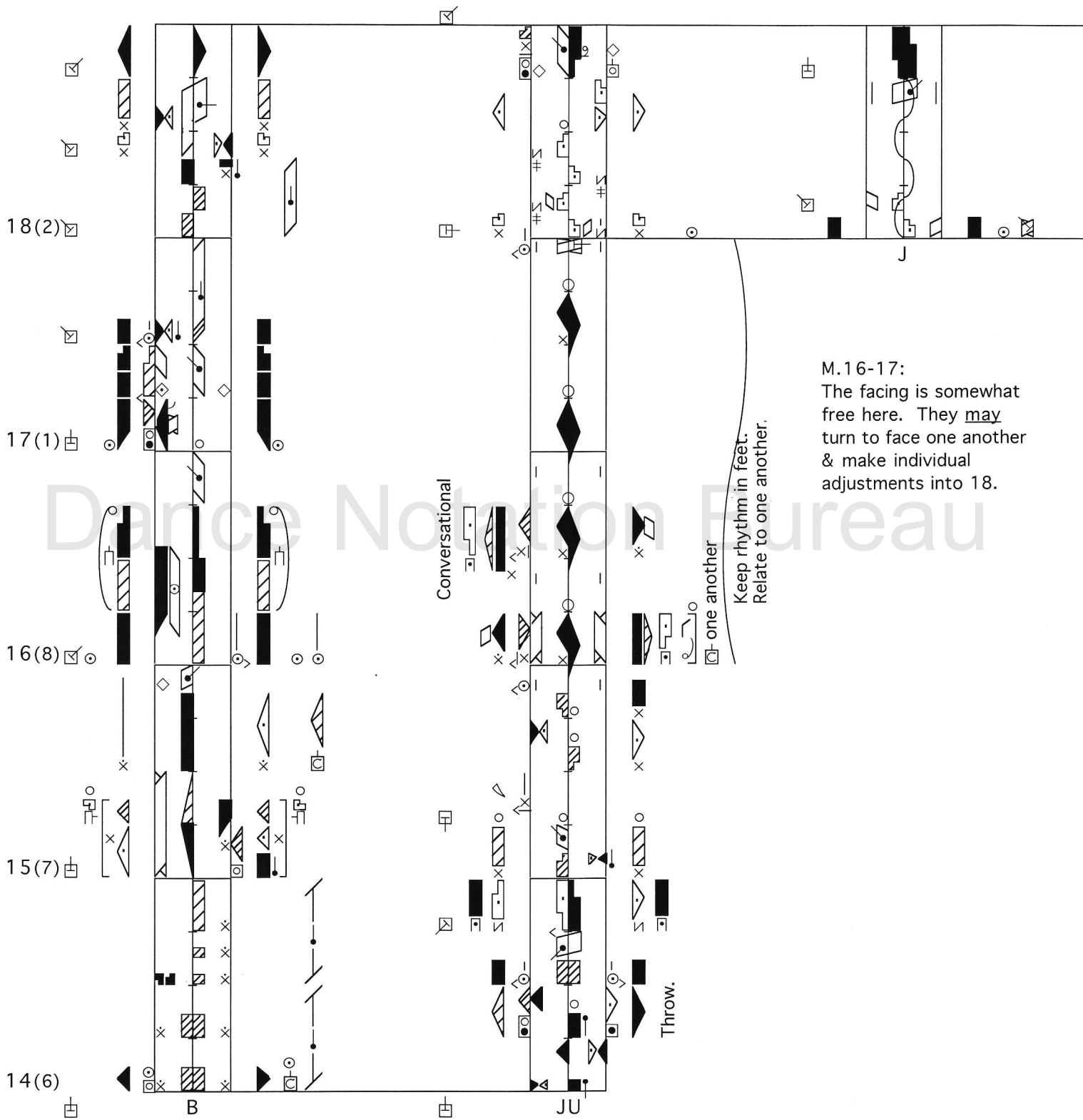

M.16-17:
 The facing is somewhat
 free here. They may
 turn to face one another
 & make individual
 adjustments into 18.

Keep rhythm in feet.
 Relate to one another.

one another

Conversational

Throw.

B

JU

J

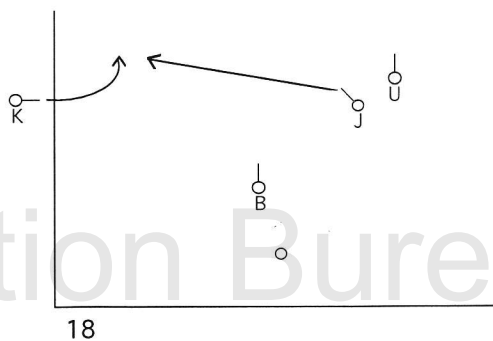
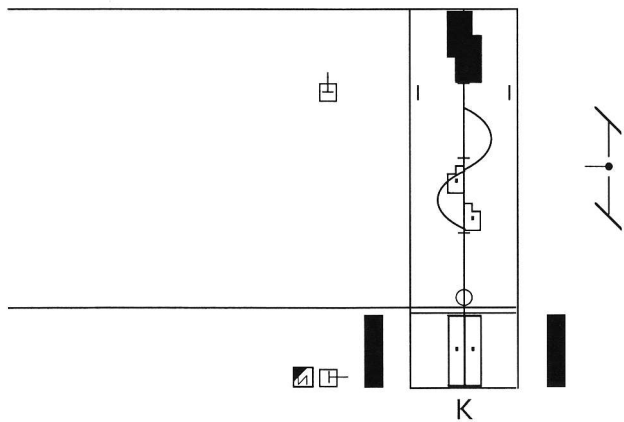

18

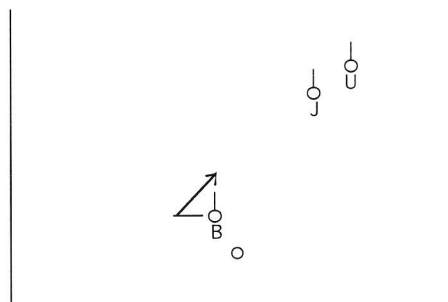

15

Dance Notation Bureau