

2 Opening March

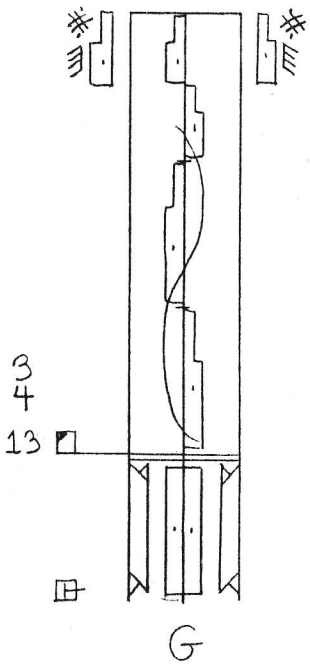

Overture M. 1-13
Slow curtain M. 9

- M. 14 = [A] 1
rein motif
- M. 15 = [A] 2
axe or sledge
hammer motif
- M. 16-17 = [A] 3
covered wagon motif
- M. 18 = [A] 4
running motif
- M 19 = [A] 5
scouting motif

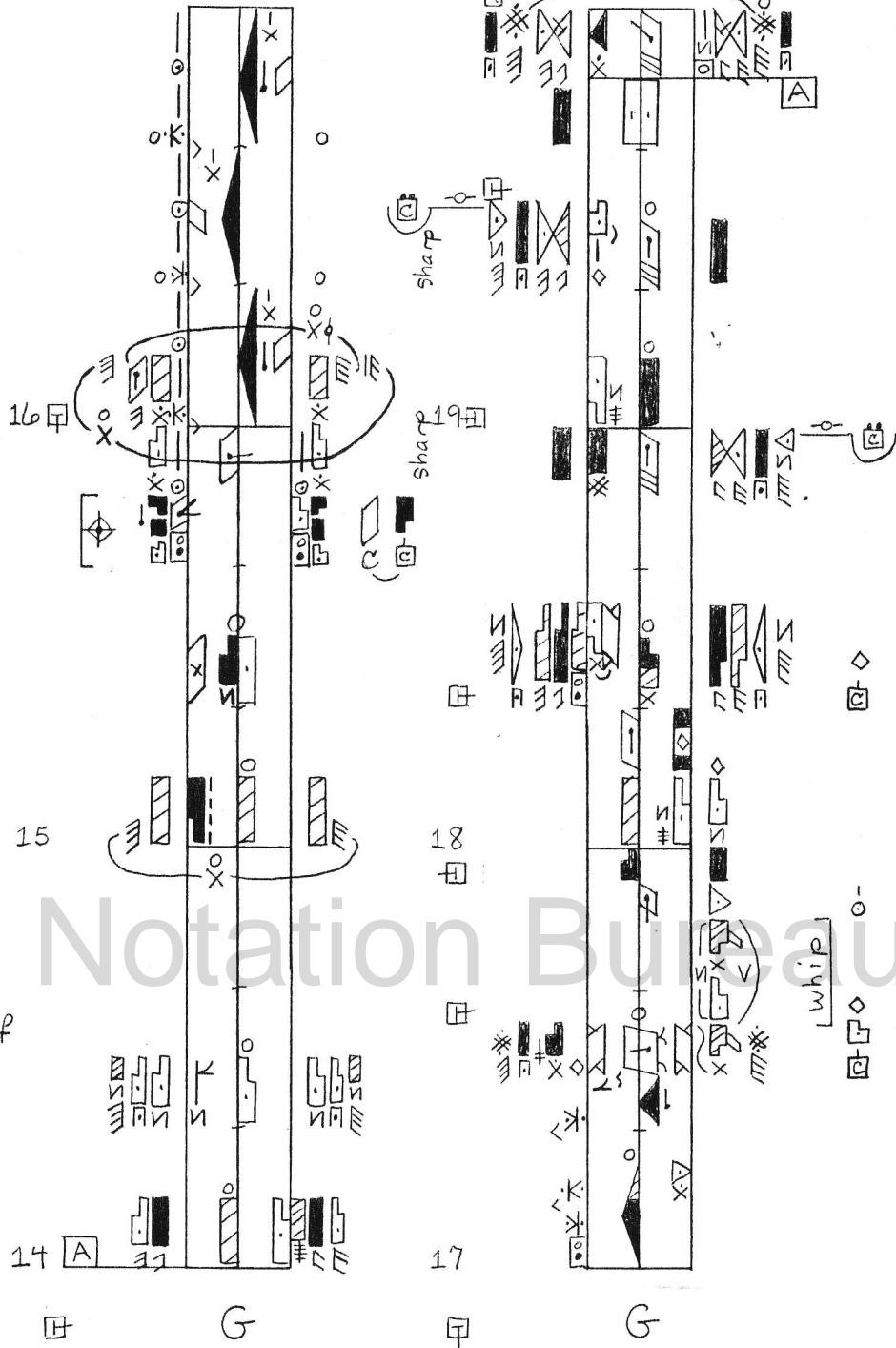

Movement of Section [A]
is assertive, direct,
weighty.

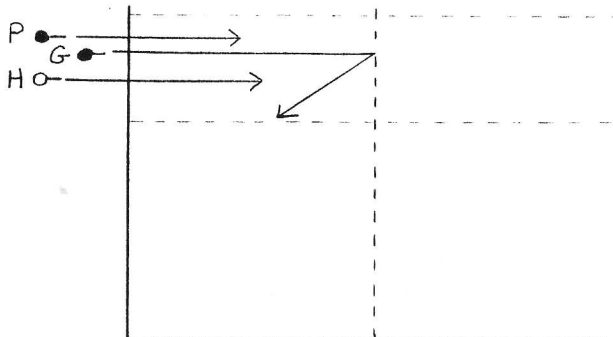

13-22

Only this area of stage is lighted by 2 pipes in the downstage right wing. The rest of the stage is dark except for down lighting on the back drop. Dancers must stay within lighted area.

scouting
22

strong
21

Break
20

Dance Notation Bureau

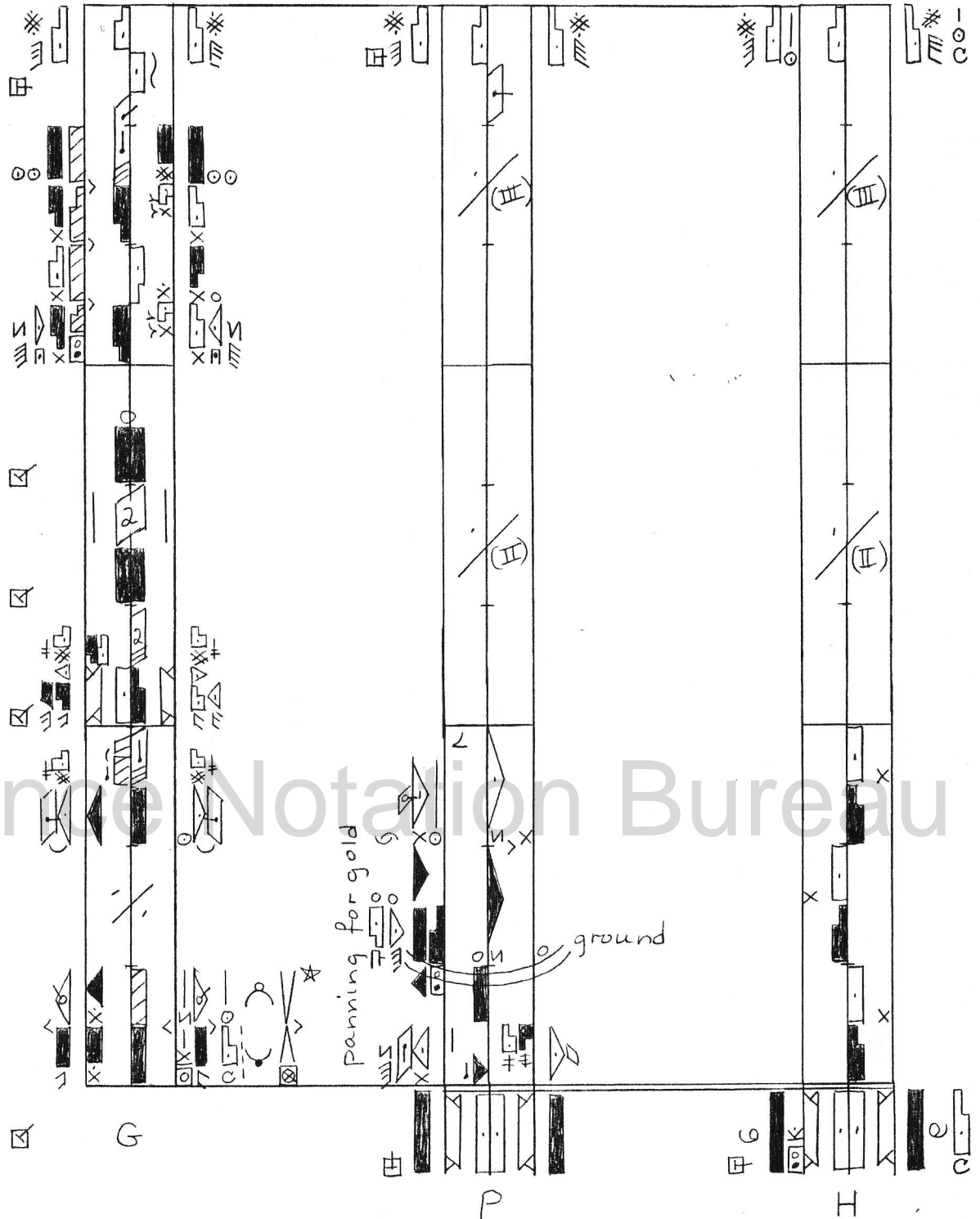

* Breath is like the involuntary sobs following heavy crying. IT should be audible,