

89₄

To facilitate this lift

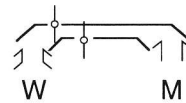

Dance Notation Bureau

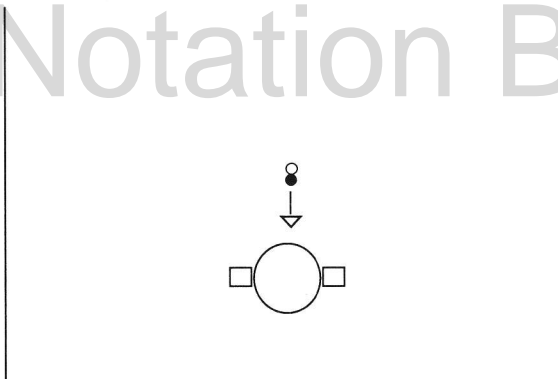

89

89

Man throws her off with a small, circular, whip-like motion of his arm.

88

- ④ She 'whips' herself around but it should look as if he does it.
- ③ He pushes (throws) her away.
- ② He lowers her. She is 'leaning' on the man.
- ① She pushes.

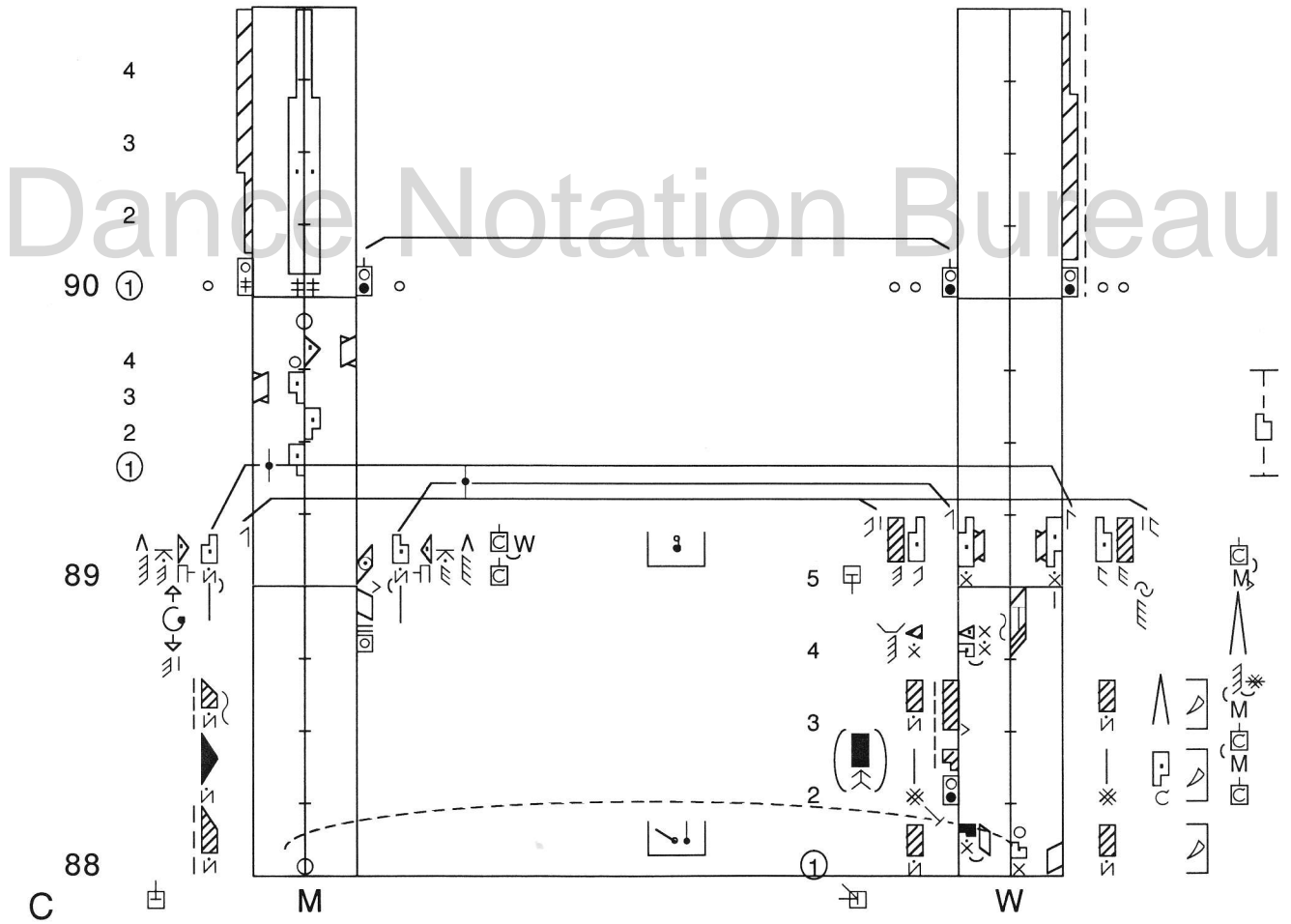
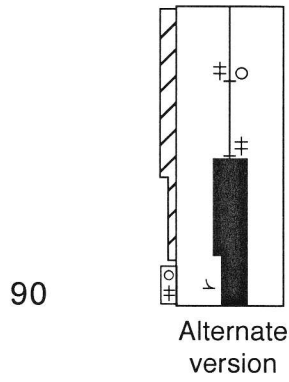

94 The only place woman can go is down - frightened.

93 Man's body is pressing against woman's so that she can slide down in m. 94.

Woman is up against the fourth wall of the house.

Dance Notation Bureau

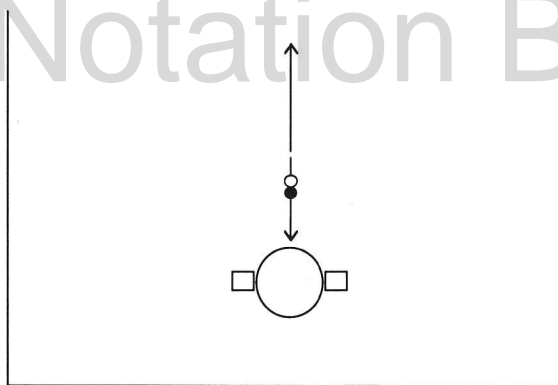

91-94 overall pattern

92 Man plays games with her.
He lifts arm to allow her to escape, knowing that he can still get her (Dayton Contemporary Dance Company).
Woman knocks his arm away (Dance Theater of Harlem).

91-93 This section was referred to as "cat and mouse."

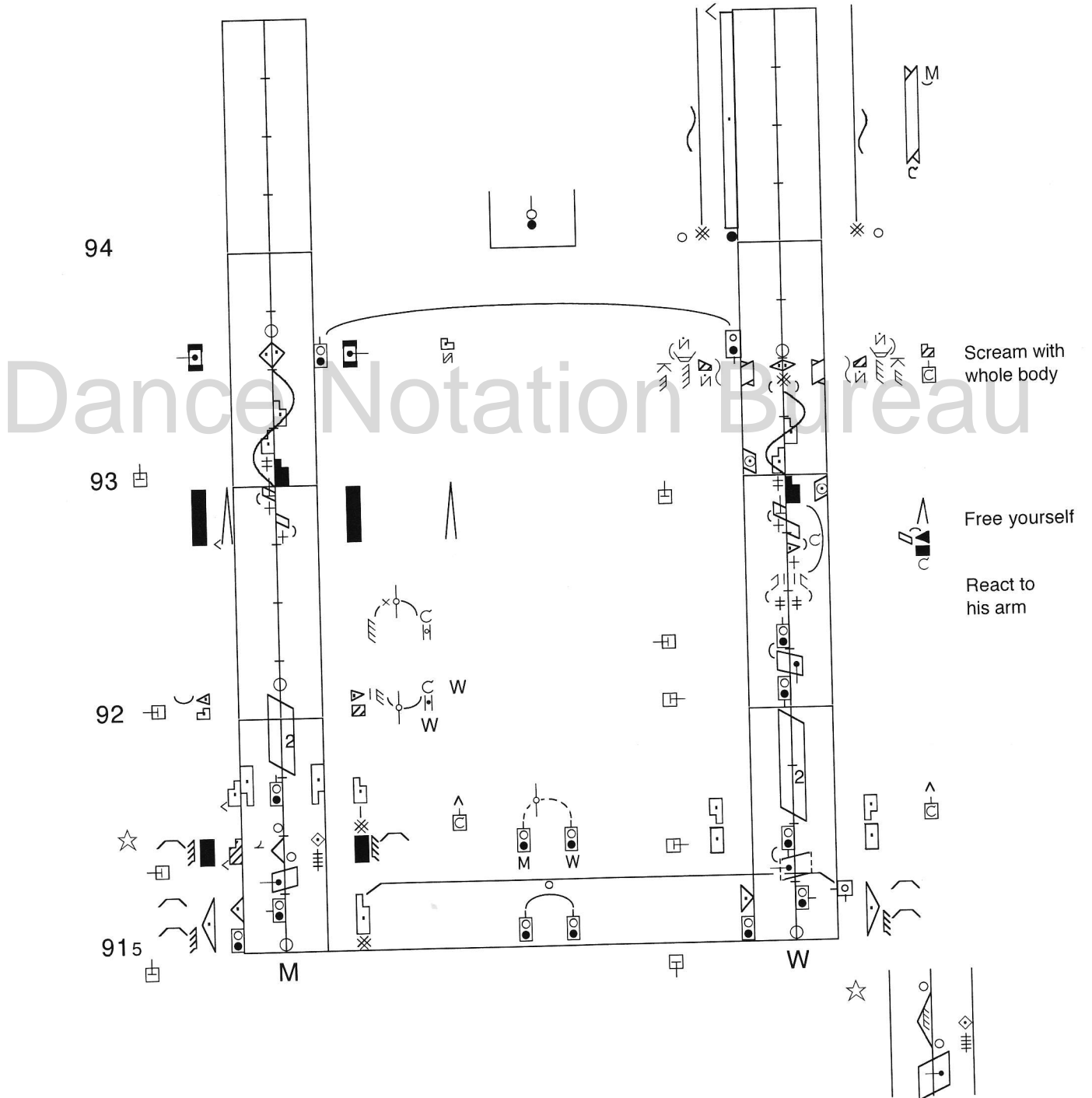

M Enlargement of m.91 ct.2