

right leg sails

Reach; gathering every child in the world

"Aunque"

11

01:26

"blanca"

12

(children)

SP: different version of movement at 11(3+).

reach

bring children toward you; protective

13

01:33

14

stay away

(children)

(children)

★ 14(1+): This look is directed toward someone who would do harm to the children --it's a warning to stay away.

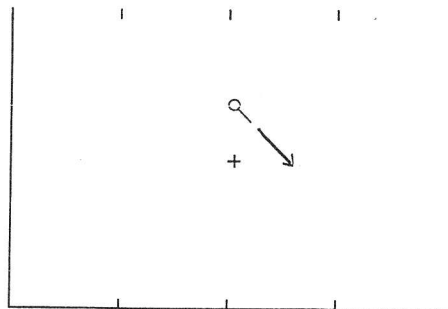

some higher force is going to crown you

take the crown in your hands

crown is heavy; arms tremble under its weight until you place it on your head; then you can carry the weight

"que tambien" "cielo"

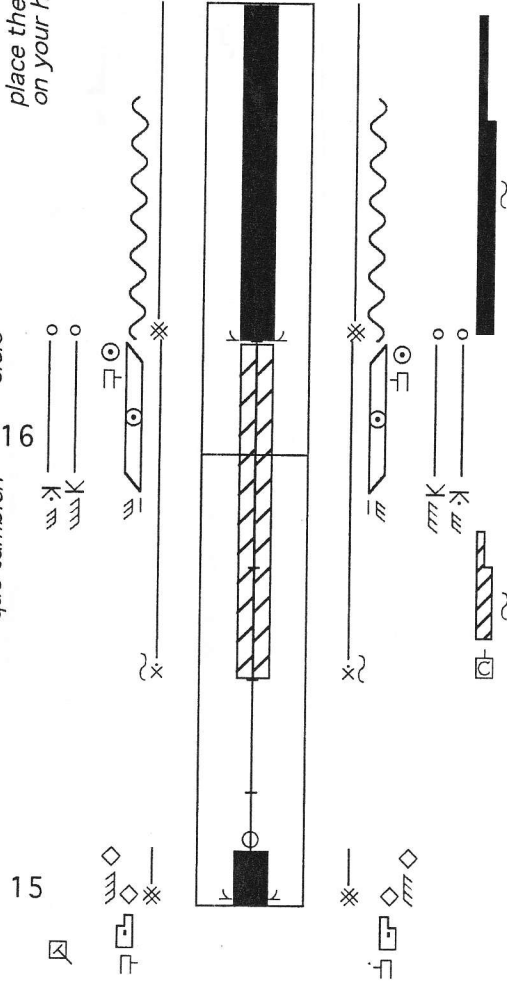

01:40 15

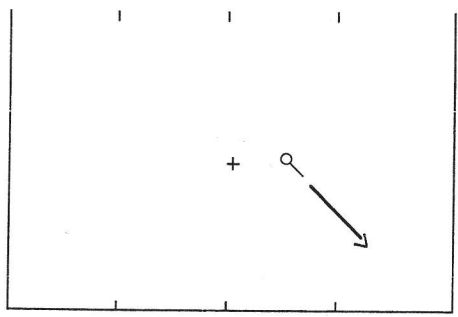

17(3)-18(2)

Looking; I still have something to do here

(higher) (higher still) (higher still)

travelling through fire and flood

arms float down unhurried

"todos" "los" "Ne-gritos" "buenos"

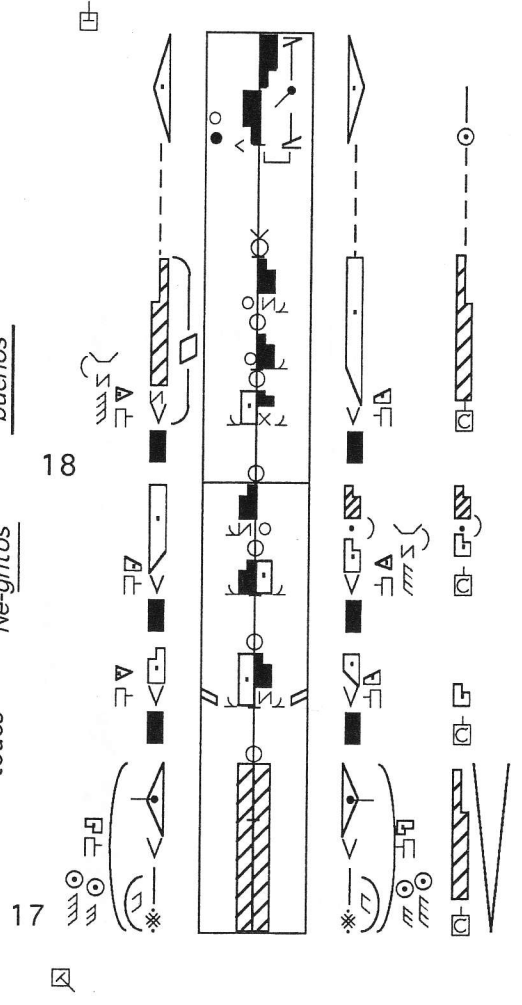

17

18

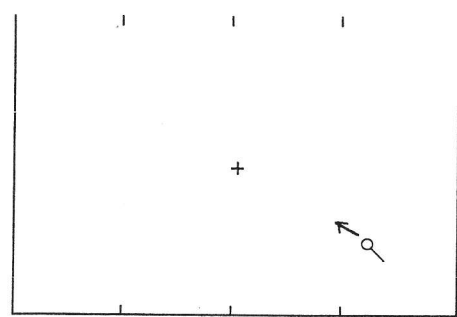

18(4)

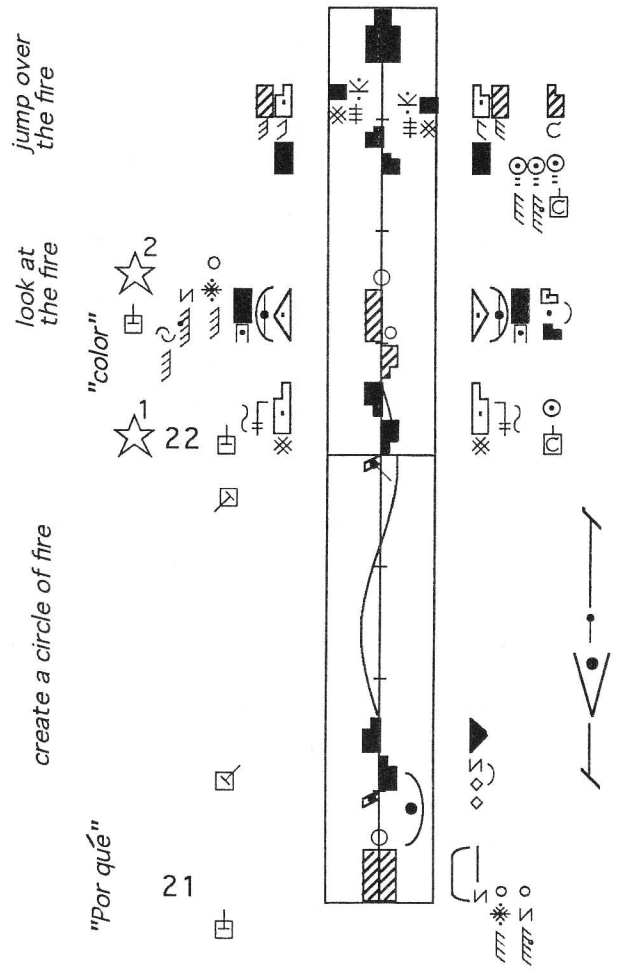
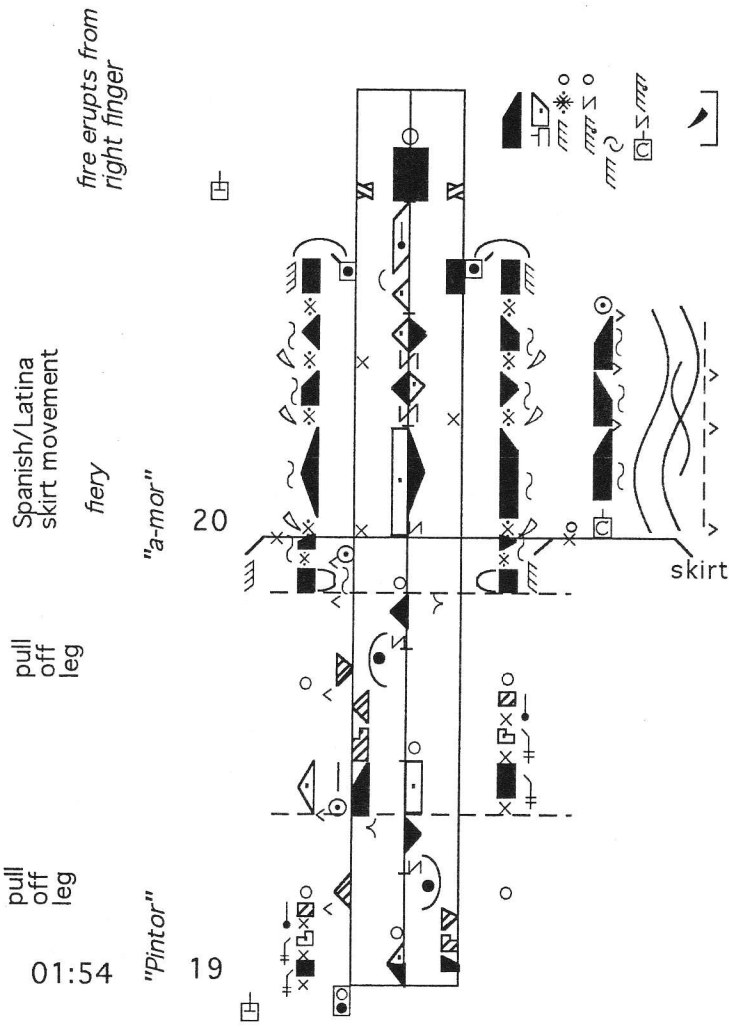

★² Alternate version, 22(2):

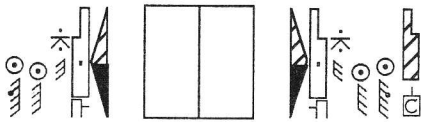

★¹ 22(1): Transitional steps to the pose at 22 (2) differ among performers (the number of steps and their direction). SP: arms and head different at 22(2).

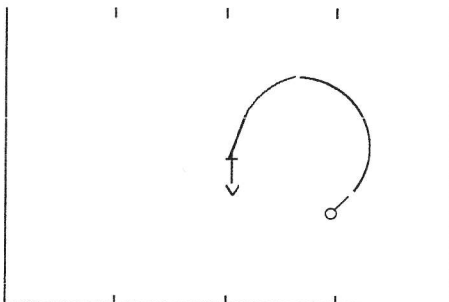

21-22(1)

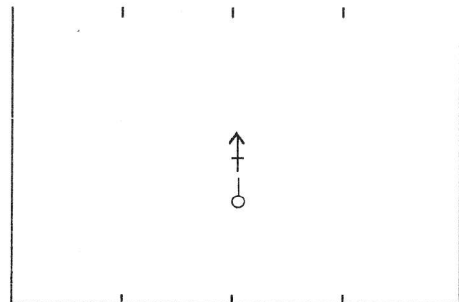

22 (3+ - 4)

"cielo"

02:08

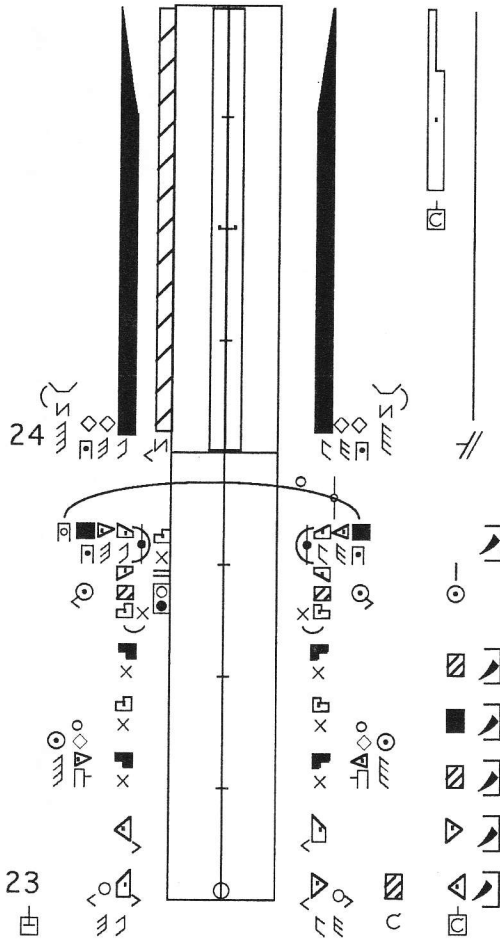

allow ankle to roll with the hip

02:15

"coba"

"pintor"

26

25

